

Multi-Force Cylinder

Air Press

Pneumatic Cylinder with Mechanical Power Transmission

When extremely high forces are required, the limits of pneumatic cylinders are quickly reached.

However most applications are subject to the same requirement: Force is only required in dead-centre position, i.e. the last millimetres of stroke!

The new TÜNKERS multi-force cylinder achieves this requirement profile through a straightforward pneumatic-mechanical solution. Its conventional pneumatic cylinder operates a toggle-joint mechanism in the dead-centre position and generates a power enhancement of 1:8.

Alternatively, this unit is available with constant force or toggle lock, safeguarding a secure end position even in the event of pressure loss. The series 40 to 80 are equipped with flat cylinders and therefore principally antirotating.

With press forces of up to 6 t (60 kN), multi-force cylinders are suitable for a multitude of tasks, such as linear positioning, clamping, embossing, clinching, punching, bending, nut piercing etc. This leaves room for applications which until currently were reserved for hydraulic systems owing to the required installation space and power requirements.



antirotating and narrow design due to flat cylinder

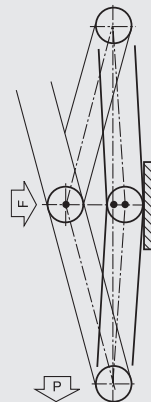
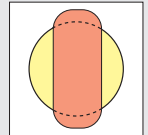

Dead-centre position locked by toggle-joint – safe positioning in case of pressure loss



Operating Principle Multi-Force Cylinder

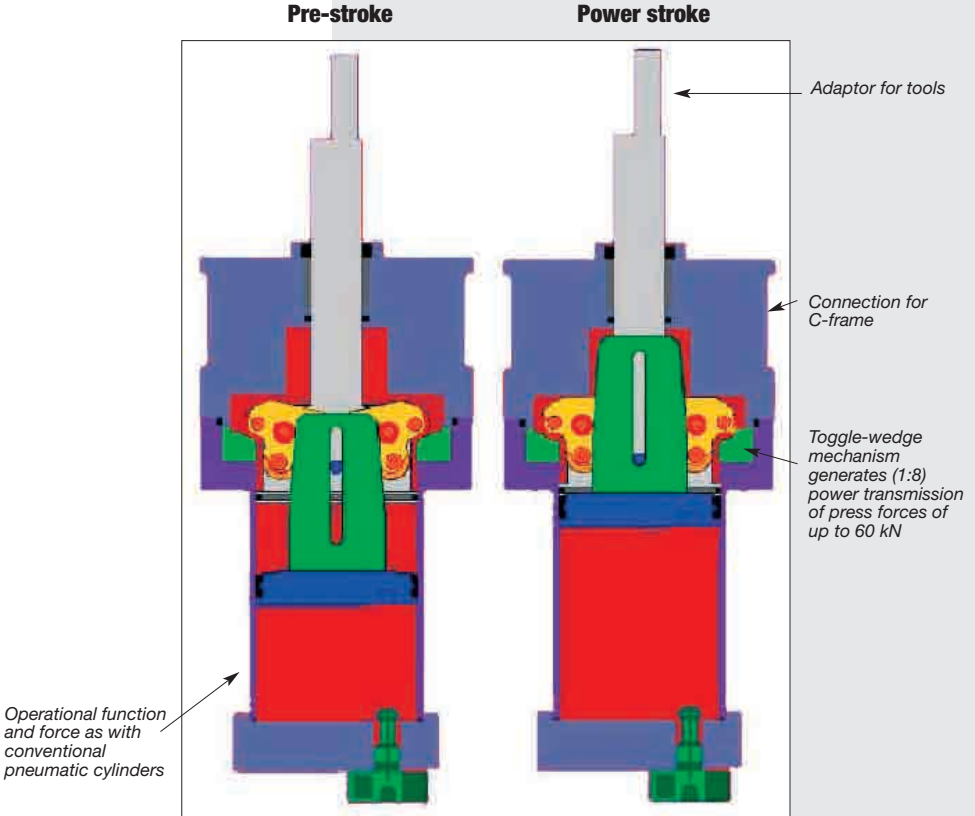

Force / Path Diagram

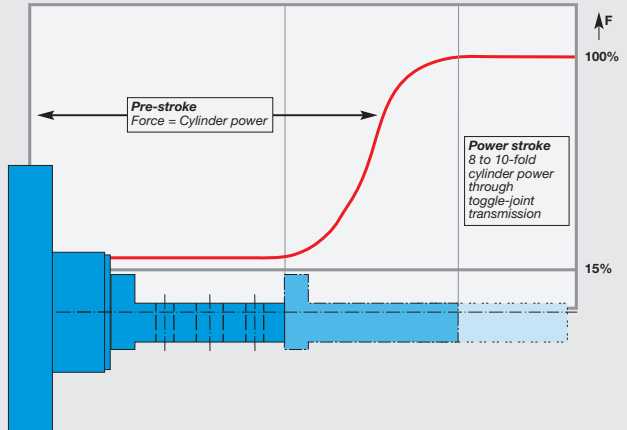

Multiple Applications



For instance: Clamping



Positioning of linear actuated fixture groups with toggle lock - replacement of entire toggle-joint constructions.

For instance: Embossing



Embossing of day, month, shift and number in steel plate

For instance: Clinching



Multi-force cylinder MZ80T in flat design for clinching operations

For instance: Nut Piercing



Multi-force cylinder MZ 140 with C-frame system for pressing of pierced nuts on the inside of doors

For instance:

Stamping, bending, cutting, welding, lifting, seaming, flanging – simple anywhere, where power is of importance in the end!

Multi-Force Cylinder MZR...



Pneumatic cylinder with mechanical power transmission in round design

- Round steel housing with integrated toggle joint transmission
- Round pneumatic cylinder
- Strokes from 50 to 300 mm

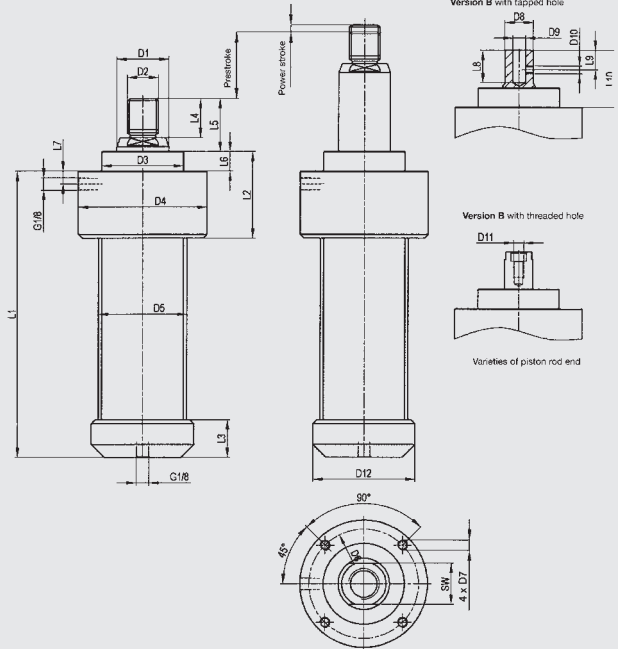

Order example:

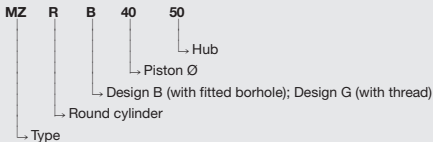

Standard fast strokes: 50; 100; 150 mm
(power stroke of 6 mm not included)

Further special strokes up to a maximum of 300 mm upon request

Type	Clamping torque power stroke at 6 bar	Power stroke mm	Fast stroke force at 6 bar	Corresp. to piston Ø mm	Weight -kg
MZR 40	4 kN	6	0,7 kN	40	1,8
MZR 63	10 kN	6	1,75 kN	63	5

Type	D1 H7	D2	D3 H7	D4	D5	D6	D7	D8 H7	D9 H7	D10	D11	D12	L1	L2
MZR 40	25	M16x1,5	40	63	45	54	M5	25	10	M6	M8	54	130+Hub	51
MZR 63	40	M24	63	99	68	85	M8	30	16	M8	M12	79	172+Hub	67

Type	L3	L4	L5	L6	L7	L8	L9	L10	SW
MZR 40	23,5	20	29	12	10	25	15	41	21
MZR 63	29	30	41	15	10	40	20	56	32

Multi-Force Cylinder MZ 40-80



Pneumatic cylinder with mechanical power transmission in flat design

- Flat housing with of high-strength aluminium
- Toggle joint transmission to amplify force on power stroke
- Driven by pneumatic flat cylinder
- Strokes from 50-150 mm
- Option position sensing

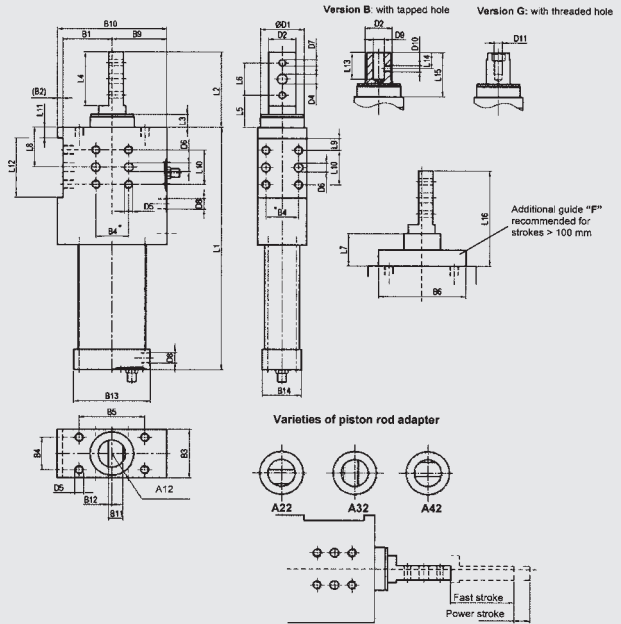

Order example:

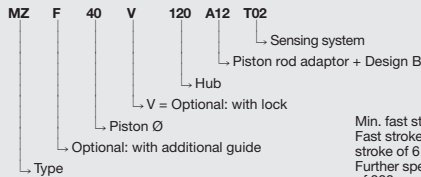

Min. fast stroke of 15 mm standard
 Fast strokes: 50, 100, 150 mm (power stroke of 6 mm not included)
 Further special strokes up to a maximum of 300 mm upon request

Type	Clamping force of power stroke kN	Power stroke mm	Fast stroke force kN at 6 bar	Pistone mm
MZ 40	4	6	0,7	40
MZ 63	10	6	1,75	63
MZ 80	28	6	2,8	80

Type	B1 ±0,02	B2	B3	B4	B5 ±0,2	B6	B9	B10	B11	B12 ±0,05	B14	D1	D2 17	D3 17	D4 17	
MZ 40	45	5	45	30	60	80	50	100	13	3	70	45	40	25	10	9
MZ 63	75	5	60	30	85	105	80	160	15	3	120	45	55	30	15	9
MZ 80	92	8	80	50	100	125	100	200	20	3	140	62	75	40	25	11

Type	D5	D6 H7	D7 H7	D8	D9 H7	D10	D11	L1	L2	L3	L4	L5	L6 ±0,02	L7	L8 ±0,05
MZ 40	M8	8	6	G1/8	10	M6	M8	195+Hub	70	12	50	30	30	45	37
MZ 63	M8	8	6	G1/8	16	M8	M12	250+Hub	70	12	50	30	30	55	37
MZ 80	M10	8	8	G1/4	20	M10/M16	340+Hub	80	20	50	40	30	81	55	

Type	L9 ±0,1	L10 ±0,1	L11	L12 ±0,1	L13	L14	L15	L16
MZ 40	11	32	10	55	25	15	41	115
MZ 63	11	32	10	55	40	20	56	125
MZ 80	15	50	15	80	40	20	80	161

Multi-Force Cylinder MZ 100/140



Pneumatic cylinder with mechanical power transmission

- Housing of high-strength aluminium
- Toggle joint transmission to amplify cylinder force on power stroke
- Driven by pneumatic round cylinder
- Strokes from 50-150 mm
- Option position sensing

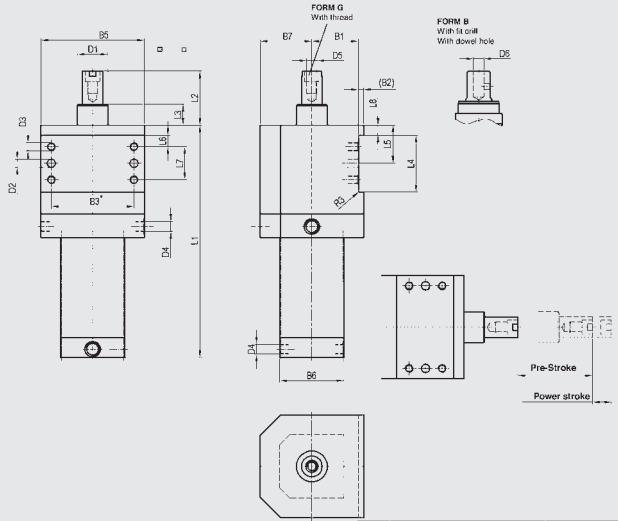

Index	Modification	Name	Datum
a	Changes in power stroke	Sr	13.02.03
b	Change in table	Sr	13.06.03
c	MZ 120 added	Sr	15.03.04
d	MZ 100 change in measures B6 ; D1 ;	Sr	15.06.05

Type	Clamping force of power stroke kN	Power stroke mm	Fast stroke force kN at 6 bar	Piston ø mm
MZ 100	40	6	4,3	100
MZ 120	60	6	6	120
MZ 140	80	6	8,5	140

Type ±0,02	B1 ±0,2	B2	B3	B4	B5	B6	B7 ±0,05	D1	D2 17	D3 17	D4 H7	D5	D6	L1	L2
MZ 100	75	15	140	42	180	114	90	63	10	M12	G1/4	M16	20	356+Hub	139
MZ 120	100	17,5	160	42	200	135	82,5	80	10	M16	G1/2	M16	20	465+Hub	139
MZ 140	107,5	17,5	210	42	250	155	125	80	10	M16	G1/2	M16	20	506+Hub	139

Type	L3	L4 -0,03 +0,02	L5 ±0,05	L6 ±0,1	L7 ±0,1	L8
MZ 100	69	80	65	15	50	25
MZ 120	69	120	85	22,5	75	25
MZ 140	69	120	85	22,5	75	25

Linear Cylinders

Linear Cylinders

TÜNKERS linear cylinders combine the pneumatic drive, an utmost precision, partially double-supported guide rod and the electric sensor in a housing of compact design. In addition, the V series types feature mechanic toggle locks.

Construction Principle

Standard Version

High precision:

very good guidance proportion due to wide support of piston rods

Manually fitted zero-clearance bronze bushings provide for precision guidance

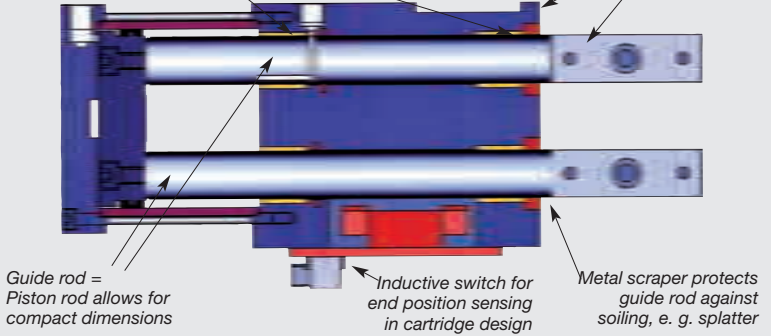

Version with mechanic toggle lock

Robust toggle-joint mechanism with rollers supported in needle-bearings



Double-guided push rod with optimal guidance proportions bronze bushings

